

SLIM Tach ST56

NorthStar™ brand

Bearingless Encoder

Key Features

- Redesigned Using Our Revolutionary Sensor Technology to Provide a Large Air Gap of 0.060"
- Redesigned Circuitry for On-Board Diagnostics with LED and Alarm Output
- Bearingless Design Mounts to 56 and 140 C-Face Motors
- Thin 3/4" Profile Saves Space and Can be "Sandwiched" Between Motor & Reducer
- Compact Height of 9.8" Designed with Options to Extend
- Anodized Aluminum Housing with Field-Serviceable Connector
- Single or Dual Isolated Outputs Available



SPECIFICATIONS

STANDARD OPERATING CHARACTERISTICS

Code: Incremental, Magnetic
Pulses per Revolution: 64-2048 PPR
Phasing Sense: A leads B for Counter-Clockwise rotation (CCW) viewing encoder-mounted end
Quadrature Phasing: 90° ± 45°
Symmetry: 180° ± 54°
Index: Less than phase A/B pulse width
Number of Output Modules: Single or Dual

ELECTRICAL

Input Voltage Requirement: 5-26 Volts DC
Current Requirement: 95 mA typical per sensor module plus line driver load
Output Signals:
 IC-WE Differential Line Driver: 150mA, sink or source
Frequency Response: 0 - 120kHz Data & Index
Noise Immunity: Tested to EN61326-1
Electrical Immunity: Reverse polarity and short circuit protected
Connector: 10 pin industrial duty latching, sealed NEMA 4 & 12, IP65; MS connector or pig-tail

MECHANICAL

Bore Size: 5/8" to 2-7/8"
Mounting Configuration: 4.5" 56 C-Face Mount or 140 C-Face Mount for NEMA MG1 Standards
Max. Shaft Speed: 7,000 RPM
Shaft Length Required: 0.7" min
Allowable Shaft End-Play: +0.050"/-0.125"
Allowable Shaft Runout: 0.005" TIR
Acceleration Rate: 3,600 rpm/sec max
Housing Material: Aluminum
Weight: 3.6 lbs.

ELECTRICAL CONNECTIONS

Signal	Connector Pin	Pigtail Cable	MS 3102E18-IT#	Conduit Box
Common	1	Black	F	1
B	2	Green	B	5
A	3	Blue	A	3
Z *	4	Violet	C	7
No Connection	5	—	E	—
Vcc (5-26 VDC)	6	Red	D	2
B	7	Yellow	I	6
A	8	Gray	H	4
Z *	9	Orange	J	8
Shield	10	Braid	G	—

* Index (Z) optional. See Ordering Information

ENVIRONMENTAL

Operating Temperature Range:
Standard: -40°C to +100°C
Extended: -40°C to +120°C
Storage Temperature Range: -40°C to +120°C
Shock: 300 G's Min.
Vibration: 20 G's @ 5-2000 Hz spectrum
Humidity: Up to 98% (non-condensing)

Ordering Information

To order, complete the model number with code numbers from the table below:

Code 1: Model	Code 2: PPR	Code 3: Index	Code 4: Wheel Bore	Code 5: Termination	Code 6: Electrical	Code 7: Cover/Adapter
□ □ □	□ □ □ □	□	□ □ □	□	□	□

Ordering Information						
ST5 Direct Motor Mounting on NEMA 56 flange (4.5"), Single Output DT5 Direct Motor Mounting on NEMA 56 flange (4.5"), Dual Output	0064 0128 0256 0512 1024 2048	L No Index Z Index	C04 0.625" CB4 16 mm C05 0.875" C36 24 mm C06 1.000" C29 25 mm C07 1.125" C31 30 mm C08 1.250" CA4 45 mm C09 1.375" C58 60 mm C10 1.500" C40 80 mm C11 1.625" C12 1.750" C13 1.875" C14 2.000" C15 2.125" C16 2.250" C17 2.375" C18 2.500" C20 2.625" C19 2.875"	B Conduit Box C Latching Industrial Connector with 1/2" NPT D 1" Extended Height Latching Industrial Connector with 1/2" NPT E 3" Extended Height Latching Industrial Connector with 1/2" NPT F Latching Industrial Connector without Mating Connector G 1" Extended Height Latching Industrial Connector H 3" Extended Height Latching Industrial Connector without Mating Connector M 10 Pin MS Connector N 10 Pin MS 3112 Connector P 18" Pigtail Cable (25" when Code 6 = H) Q Latching Industrial Connector on 18" Pigtail Cable R Latching Industrial Connector on 18" Pigtail Cable without Mating Connector	V 5-26V in, 5-26V Line Driver (IC-WE) out 5 5-26V in, 5V out Line Driver (IC-WE) H Same as V but with High Temperature, Extended Operating Range to 120°C	CC Plastic Cover EE Extra Heavy Duty Steel Cover FF Flat Thru-Hole Cover TT Flat No Hole Cover
		For additional bore sizes up to 3.75" maximum, please consult factory.				

Note: See ACCESSORIES Section For Connectors, Spare Parts and Pulse Wheels

SL56 LEGACY MODELS

Dynapar's legacy SL56 product line is still available for configurations not currently available in the ST56 product line. For additional bore sizes up to 3.75" maximum, please consult the factory.

SLIM Tach ST56



DIMENSIONS inches

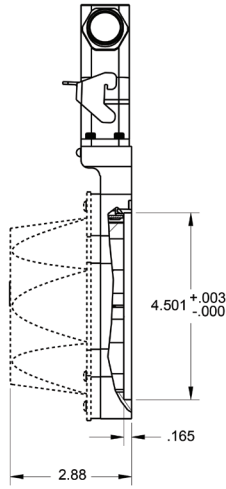
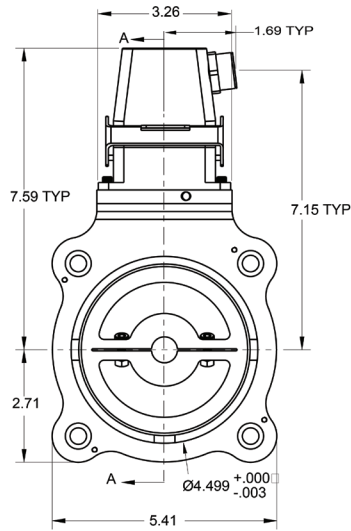

SECTION A-A
PLASTIC COVER OPTION

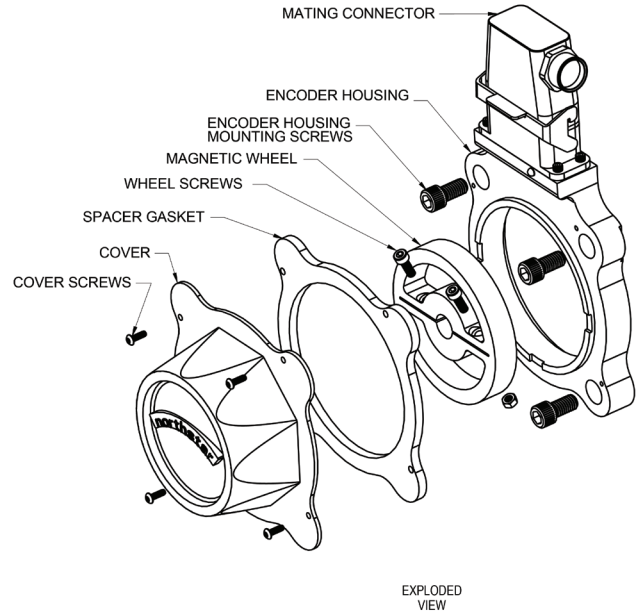

EXPLODED
VIEW